

SBT-1KL

"SBT-1KL" SERIES SHEAR BEAM NICKEL-PLATED LOAD CELLS, from 500kg to 2500kg



Dini Argeo nickel-plated approved load cells, with low-power 1000 Ohm output resistance for mobile battery applications.

The measures are compatible with the main shear beam load cells present on the market. They are suitable for creating CE-M approved scales with 4 load cells or for weighing conveyors, tanks and hoppers, thanks to their accessories.

CAPACITIES (kg): 500, 1000, 2000, 2500.

OIML R60 approved, NTEP.

Nickel-plated steel. **IP67** protection.

Output Resistance **1000 Ohm**.

The best solution
for advanced industrial
applications

MAIN FEATURES

- C3 PRECISION CLASS
- NICKEL-PLATED CONSTRUCTION
- POTTED SEAL, IP67 PROTECTION
- MAX. CAPACITIES FROM 500 TO 2500 kg
- SHIELDED CONNECTION CABLE
- TEST CERTIFICATE AVAILABLE UPON REQUEST

TECHNICAL FEATURES

- Minimum load cell verification interval $V_{min} = E_{Max} / 10.000$
- Maximum number of verification intervals $n_{LC} = 3000$
- Combined error 0,017% of Full Scale Output (F.S.)
- Nonlinearity $\pm 0.02\%$ FS
- Hysteresis $\pm 0.02\%$ FS
- Repeatability $\pm 0.01\%$ FS
- Full Scale Output $2mV/V \pm 0.5\%$
- Zero balance $\pm 1\%$ FS
- Compensated Temperature Range $-10^{\circ}C/+50^{\circ}C.$
- Operating Temperature Range $-20^{\circ}C/+60^{\circ}C.$
- Creep error after 30 minutes $<0,02\%$ F.S.
- Maximum tolerated excitation voltage 15 Vdc
- Input Resistance 1085 ± 10 Ohm
- Output Resistance 1000 ± 5 Ohm
- Insulation Resistance >5000 MOhm
- Safe Overload 120% F.S.
- Ultimate Overload 300% F.S.
- 6-wire shielded cable, 3,5m long, 5 mm diameter

MAIN CERTIFICATIONS

- OIML R60
- NTEP
- Australian legal for trade certificate of approval (NMI S839)

DIMENSIONS - DECODING STANDARD CABLE

- NOTE: dimensions in mm

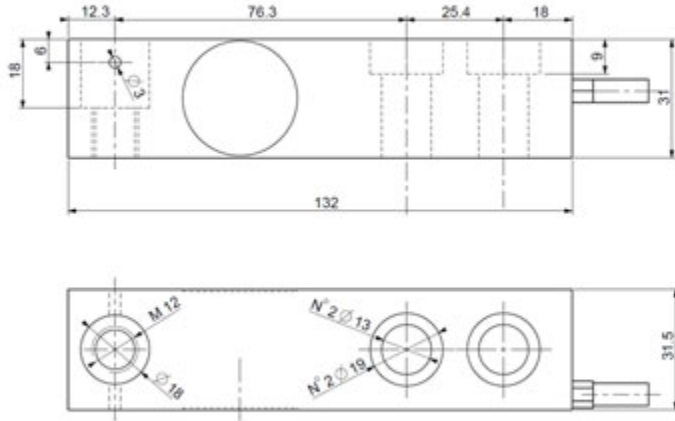

- Decoding of the standard cable colours

Colour	Function
--	SHIELD
YELLOW	OUTPUT +
GREY	SENSE +
BROWN	INPUT +
WHITE	OUTPUT -
GREEN	INPUT -
PINK	SENSE -

VERSIONS

Available versions

Code	Max (kg)
SBT500-1KL 	500
SBT1000-1KL 	1000
SBT2000-1KL 	2000
SBT2500-1KL 	2500



“YOUR WORLDWIDE PARTNER FOR WEIGHING”

DINI ARGEO
FRANCE sarl
France

DINI ARGEO
GMBH
Germany

DINI ARGEO
UK Ltd
United Kingdom

DINI ARGEO WEIGHING
INSTRUMENTS Ltd
China

DINI ARGEO
OCEANIA
Australia



COMPANY HEADQUARTERS

Via Della Fisica, 20
41042 Spezzano di Fiorano Modena • Italy
Tel. +39.0536 843418

SERVICE ASSISTANCE

Via Dell'Elettronica, 15
41042 Spezzano di Fiorano Modena • Italy
Tel. +39.0536 921784

SALES AND TECHNICAL ASSISTANCE SERVICE