

Dolphin Series

Checkweighers



A&D ...Clearly a Better Value

A&D MERCURY PTY. LTD.

<http://www.andmercury.com.au>



ADM 4404-LC Series of Dolphin Checkweighers

The ADM 4404 LC light capacity series of Dolphin checkweighers are manufactured from stainless steel to suit the requirements of HACCP, they are suitable for chemical, pharmaceutical and food industries. The checkweighers can be configured to suit a wide range of products for medium speed packaging lines, with a weighing range of up to 2000 grams.



Trade Approval Pending.
Images for illustrations only.

4404-LC Features:

- Light capacities up to 2000 grams
- Maximum speed 100p/m
- Compact stainless steel design
- Easy cleaning and maintenance
- Designed to meet HACCP requirements
- Weight classification of 5 zones and alarm
- Customisable operator display
- Designed and manufactured in Australia
- Standard version - 10 Products
- Intelligent version - 100 Products
- Standard RS485 ASCII serial I/O
- Standard Current Loop Serial Output

** Customised sizes and speeds on application*



Simplified Maintenance

The open tubular frame minimises surface areas for dust and debris to accumulate. The 'non tool' quick conveyor release mechanism allows for simple ease of access for maintenance.

Electrical Options

- Fieldbus - DeviceNet, Profibus, Modbus and Ethernet
- Analog - 4-20mA and 0-10VDC
- Metal detection Interface

Mechanical Options

- Reject Mechanism - Flipper, Air Blast, Drop Conveyor
- Conveyor Product Guides
- Breeze (wind) break
- Transfer Plate
- Combination Checkweigher/Metal Detector

Models	4404LC-200	4404LC-500	4404LC-1000	4404LC-1500	4404LC-2000
Capacity	200g	500g	1000g	1500g	2000g
Accuracy	±0.1g	±0.2g	±0.2g	±0.5g	±0.5g
Max. Speed	1m/s	1m/s	1m/s	1m/s	1m/s
Belt Length (mm)	200, 300	200, 300	300, 400	300, 400	300, 400
Belt Width (mm)	150	150, 200	200, 300	200, 300	200, 300
Width (mm)	750	750, 800	800, 900	800, 900	800, 900
Height (mm)	900 +/- 50	900 +/- 50	900 +/- 50	900 +/- 50	900 +/- 50
Gross Weight	Approx. 110Kg	Approx. 110Kg	Approx. 112Kg	Approx. 112Kg	Approx. 112Kg
Environment	-5 to +40° relative humidity less than 85% RH, non condensing (Variation not to exceed 5° C/h)				
Protection	IP65 Compliance - Dust and Low pressure jets of water from all directions				
Manufacture	Stainless Steel (SUS304)				

** The speed and accuracy may change depending on the checked product type and reject mechanism.*

ADM 4404-HC Series of Dolphin Checkweighers

The ADM 4404-HC high capacity series of Dolphin checkweighers are manufactured from stainless steel to suit the requirements of HACCP, they are suitable for chemical, pharmaceutical and food industries. The checkweighers can be configured to suit a wide range of products for medium speed packaging lines, with a weighing range of up to 30 kilograms.



Trade Approval
Pending.
Images for
illustrations only.

4404-HC Features:

- High capacities up to 30.000 Kilograms
- Maximum speed 30p/m
- Compact stainless steel design
- Easy cleaning and maintenance
- Designed to meet HACCP requirements
- Weight classification of 5 zones and alarm
- Customisable operator display
- Designed and manufactured in Australia
- Standard version - 10 Products
- Intelligent version - 100 Products
- Standard RS485 ASCII serial I/O
- Standard Current Loop Serial Output

** Customised sizes and speeds on application*

Simplified Maintenance

The open tubular frame minimises surface areas for dust and debris to accumulate. The quick removal of conveyors allows for simple ease of access for maintenance.

Electrical Options

- Fieldbus - DeviceNet, Profibus, Modbus and Ethernet
- Analog - 4-20mA and 0-10VDC
- Metal detection Interface

Mechanical Options

- Reject Mechanism - Flipper, Air Blast, Drop Conveyor
- Conveyor Product Guides
- Breeze (wind) break
- Transfer Plate
- Combination Checkweigher/Metal Detector

Models	4404HC-10	4404HC-20	4404HC-30
Capacity	10.000Kg	20.000Kg	30.000Kg
Accuracy	±0.004Kg	±0.010Kg	±0.010Kg
Max. Speed	0.5m/s	0.5m/s	0.5m/s
Belt Length (mm)	500, 1000	500, 1000	500, 1000
Belt Width (mm)	300, 500	300, 500	300, 500
Width (mm)	1010	1010	1010
Height (mm)	900 +/- 50	900 +/- 50	900 +/- 50
Gross Weight	Approx. 210Kg	Approx. 210Kg	Approx. 210Kg
Environment	-5 to +40° relative humidity less than 85% RH, non condensing (Variation not to exceed 5° C/h)		
Protection	IP65 Compliance - Dust and Low pressure jets of water from all directions		
Manufacture	Stainless Steel (SUS304)		

** The speed and accuracy may change depending on the checked product type and reject mechanism.*

ADM 4820-LC Series of Dolphin Checkweighers

The ADM 4820-LC light capacity series of Dolphin checkweighers are manufactured from stainless steel to suit the requirements of HACCP, they are suitable for chemical, pharmaceutical and food industries. The checkweighers can be configured to suit a wide range of products for high speed packaging lines, with a weighing range of up to 3000 grams, custom capacities are available on request.



4820-LC Features:

- Light capacities up to 3000 grams
- Maximum speed 250p/m
- Touch Colour STN IP65 Waterproof screen
- Advanced remote Ethernet data management
- Customisable Multi-Lane Checkweighing
- Compact stainless steel design
- Easy cleaning and maintenance
- Designed to meet HACCP requirements
- Weight classification of 7 zones and alarm
- Designed and manufactured in Australia
- Standard version - 100 Products
- Intelligent version - 200 Products

* Customised sizes and speeds on application

Simplified Maintenance

The open tubular frame minimises surface areas for dust and debris to accumulate. The 'non tool' quick conveyor release mechanism allows for simple ease of access for maintenance.

Electrical Options

- Fieldbus - DeviceNet, Profibus, Modbus and Ethernet
- Analog - 4-20mA and 0-10VDC
- Metal detection Interface
- Temperature data recording & indication to suit HACCP

Mechanical Options

- Reject Mechanism - Flipper, Air Blast, Drop Conveyor
- Conveyor Product Guides
- Breeze (wind) break
- Transfer Plate
- Combination Checkweigher/Metal Detector

Simplified Operation

The operation has been simplified by the use of 'one-touch' easy to read operator screens and keypads.



Models	4820LC-200	4820LC-500	4820LC-1000	4820LC-1500	4820LC-3000
Capacity	200g	500g	1000g	1500g	2000g
Accuracy	±0.05g	±0.1g	±0.1g	±0.2g	±0.2g
Max. Speed	2m/s	2m/s	2m/s	2m/s	2m/s
Belt Length (mm)	200, 300	200, 300	300, 400	300, 400	300, 400
Belt Width (mm)	150	150, 200	200, 300	200, 300	200, 300
Width (mm)	750	750, 800	800, 900	800, 900	800, 900
Height (mm)	900 +/- 50	900 +/- 50	900 +/- 50	900 +/- 50	900 +/- 50
Gross Weight	Approx. 110Kg	Approx. 110Kg	Approx. 112Kg	Approx. 112Kg	Approx. 112Kg
Environment	-5 to +40° relative humidity less than 85% RH, non condensing (Variation not to exceed 5° C/h)				
Protection	IP65 Compliance - Dust and Low pressure jets of water from all directions				
Manufacture	Stainless Steel (SUS304)				

* The speed and accuracy may change depending on the checked product type and reject mechanism.

ADM 4820-HC Series of Dolphin Checkweighers

The ADM 4820-HC high capacity series of Dolphin checkweighers are manufactured from stainless steel to suit the requirements of HACCP, they are suitable for chemical, pharmaceutical and food industries. The checkweighers can be configured to suit a wide range of products for high speed packaging lines, with a weighing range of up to 100 kilograms.



4820-HC Features:

- High capacities up to 100 Kilograms
- Maximum speed 60p/m
- Touch Colour STN IP65 Waterproof screen
- Advanced remote Ethernet data management
- Customisable Multi-Lane Checkweighing
- Compact stainless steel design
- Easy cleaning and maintenance
- Designed to meet HACCP requirements
- Weight classification of 7 zones and alarm
- Designed and manufactured in Australia
- Standard version - 100 Products
- Intelligent version - 200 Products

* Customised sizes and speeds on application

Simplified Maintenance

The open tubular frame minimises surface areas for dust and debris to accumulate. The 'non tool' quick removal of conveyors allows for simple ease of access for maintenance.

Electrical Options

- Fieldbus - DeviceNet, Profibus, Modbus & Ethernet
- Analog - 4-20mA and 0-10VDC
- Metal detection Interface
- Temperature data recording & indication to suit HACCP

Mechanical Options

- Reject Mechanism - Flipper, Air Blast, Drop Conveyor
- Conveyor Product Guides
- Breeze (wind) break
- Transfer Plate
- Combination Checkweigher/Metal Detector

Simplified Operation

The operation has been simplified by the use of 'one-touch' easy to read operator screens and keypads.

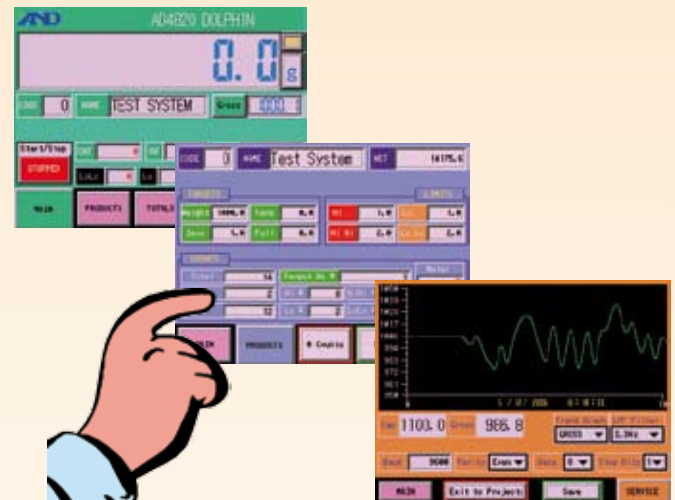

Models	4820HC-10	4820HC-20	4820HC-30	4820HC-60	4820HC-100
Capacity	10.000Kg	20.000Kg	30.000Kg	60.000Kg	100.000Kg
Accuracy	±0.002Kg	±0.004Kg	±0.010Kg	±0.020Kg	±0.020Kg
Max. Speed	1m/s	1m/s	1m/s	1m/s	1m/s
Belt Length (mm)	500, 1000	500, 1000	500, 1000	500, 1000	500, 1000
Belt Width (mm)	300, 500	300, 500	300, 500	300, 500	300, 500
Width (mm)	1000	1000	1000	1200	1200
Height (mm)	900 +/- 50	900 +/- 50	900 +/- 50	900 +/- 50	900 +/- 50
Gross Weight	Approx. 210Kg	Approx. 210Kg	Approx. 210Kg	Approx. 210Kg	Approx. 210Kg
Environment	-5 to +40° relative humidity less than 85% RH, non condensing (Variation not to exceed 5° C/h)				
Protection	IP65 Compliance - Dust and Low pressure jets of water from all directions				
Manufacture	Stainless Steel (SUS304)				

* The speed and accuracy may change depending on the checked product type and reject mechanism.

General Dimensions

4404 & 4820 - Light Capacity

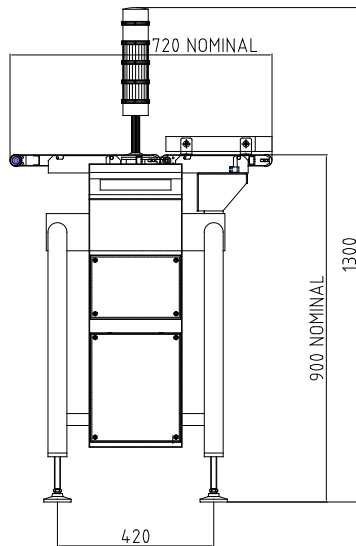

4404 & 4820 - Heavy Capacity

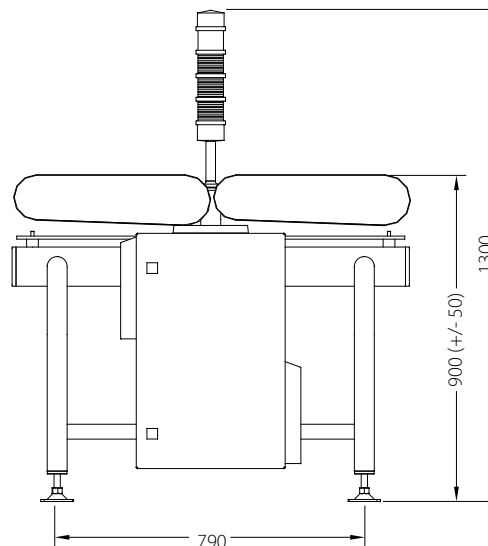

Options

ADM Dolphin Rejection Methods

- Flipper pneumatic reject
- Air blast pneumatic reject
- Drop pneumatic conveyor reject
- Custom designs on application



ADM Multi-Weigher Data Capture Software

Stop and start checkweighers remotely and capture live weight data from 5 checkweighers and 255 weighing scales

ADM Metal Detection

Metron AMD 05A slim line touch Reject interface to checkweigher
Stainless steel detector
Conveyor widths 500mm
Aperture height up to 400mm



ADM Production Data Display

High visibility 16 x 80 Red dot LED display
"Real-time" production data displayed
Checked products, product status and grand total accumulated gross weight



A&D MERCURY PTY. LTD.
ACN 007 556 809

Head Office
32 Dew Street
THEBARTON
South Australia 5031
Telephone (08) 8301 8100
Facsimile (08) 8352 7409

Victorian Office
Unit 4, 313 Arden Street
KENSINGTON
Victoria 3031
Telephone (03) 9372 1522
Facsimile (03) 9372 1193

New South Wales Office
Unit 4, 14 Abbott Road
SEVEN HILLS
New South Wales 2147
Telephone (02) 9674 5466
Facsimile (02) 9674 2544

Email: salesinquiry@andmercury.com.au
Internet page: <http://www.andmercury.com.au>

Your Dealer