

Belt Weighing System

ASSOCIATED
SCALE SERVICES
www.associatedscales.com.au 07 3272 0077



Australian Design

ASBW Belt Weighing System

Description

Australian Built

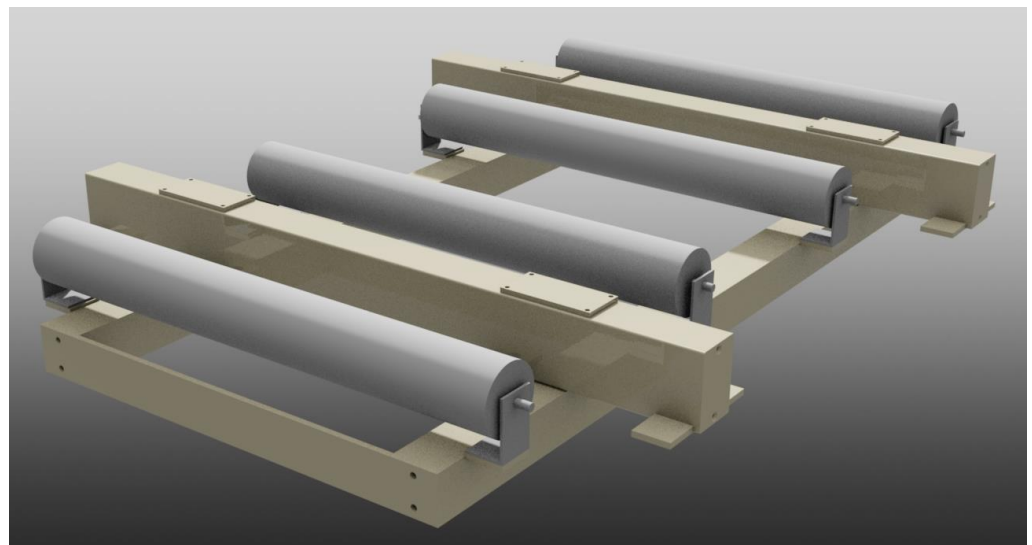

Internal Components readily available

Controllers able to be optioned for most Comms

Custom Built at the cost of an off the shelf Belt Weighing System
(Note: Rollers/Idlers are not included in the standard set up)

Associated Scale Services Pty Ltd
Ph: +61 (0)7 3272 0077
Email: info@associatedscales.com.au
Web: www.associatedscales.com.au

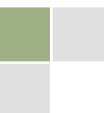

Specifications

Capacity	Designed to suit
Idler	2 idler / 3 idler / 4 idler
Load Cells	ANYLOAD 101BH (readily available through Associated Scale Service)
Display Type	Ricelake 920i / GSE 662
Power	240VAC (Clean power - UPS is recommended)

The ASBW consists of a sub frame designed to fit directly into the existing system with the idler system fitted within the frame.

Each idler is supported by 2 S type load cells in a

For a full quotation please refer to questionnaire ASBW-02. The information gathered will assist the sales engineer to quote the relevant system.

